

2 CONDUCTIVE POLYMER HYBRID ALUMINUM ELECTROLYTIC CAPACITORS



CONDUCTIVE POLYMER HYBRID ALUMINUM ELECTROLYTIC CAPACITORS

1. Conductive Polymer Hybrid Aluminum Electrolytic Capacitor?

Conductive Polymer Hybrid Capacitor consist of Conductive Polymer Electric materials and Liquid Electrolyte as Electrolyte

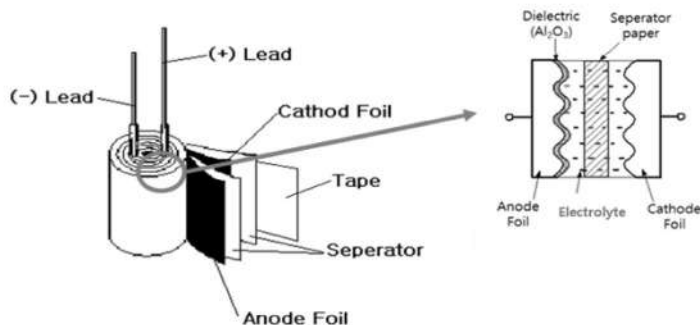

Section	Electrolytic Cap.	Solid Cap.	Hybrid Cap.
Electrolyte	Liquid Electrolyte	Conductive Polymer	Conductive Polymer + Liquid Electrolyte

2. Merits of Conductive Polymer Hybrid Aluminum Electrolytic Capacitor

By using conductive polymer as electrolyte, low ESR characteristics and high ripple characteristics can be realized. Low leakage current and short defect of capacitor can be prevented by electrolytic solution.

3. Characteristic

Section	Electrolyte Cap.	Solid Cap.	Hybrid cap.
SIZE	O	△	◎
ESR	X	O	◎
TEMPERATURE	X	O	◎
DISSIPATION FACTOR	X	O	◎
RIPPLE CURRENT	X	O	◎
RELIABILITY	X	O	◎
LEAKAGE CURRENT	O	X	◎

◎ Excellent O Good △ Average X Weak

● Taping Specifications for Chip Type Capacitors

● Carrier Tape

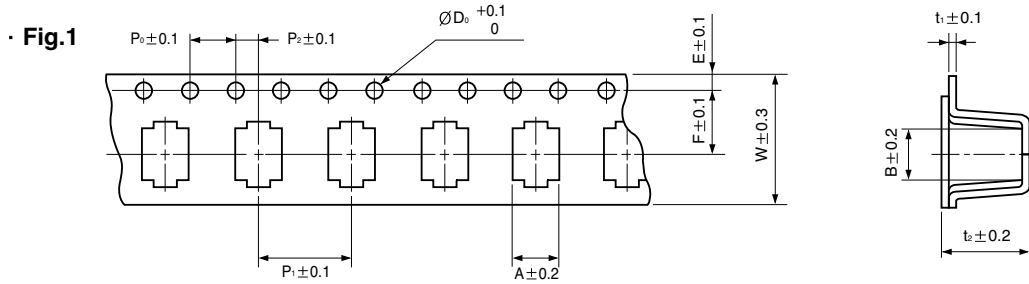

ØD×L	A	B	ØD ₀	E	F	P ₀	P ₁	P ₂	t ₁	t ₂	W
6.3 × 7.7	7.0	7.0	1.5	1.75	7.5	4.0	12.0	2.0	0.4	8.3	16.0
8 × 10	8.7	8.7	1.5	1.75	11.5	4.0	16.0	2.0	0.4	11.1	24.0
10 × 10	10.7	10.7	1.5	1.75	11.5	4.0	16.0	2.0	0.4	11.1	24.0
10 × 12.5	10.7	10.7	1.5	1.75	11.5	4.0	16.0	2.0	0.5	13.1	24.0

HYBRID TYPES

● Reel (Taping code : VR, VG)

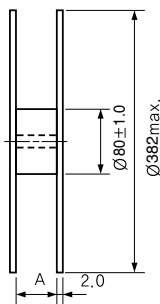
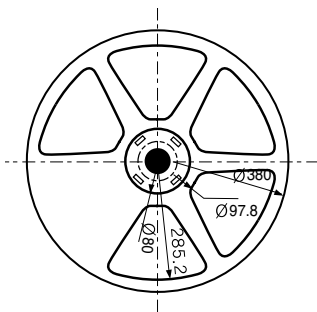

● Polarity

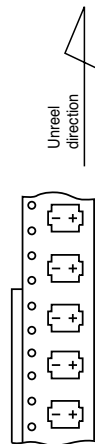

● Recommended Land Size

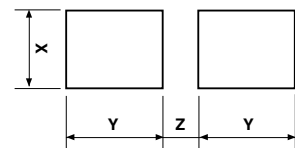

ØD×L	A	ØD×L	Q'ty/Reel(pcs.)	Q'ty/Box(pcs.)
6.3 × 7.7	16	6.3 × 7.7	900	9000
8 × 10	24	8 × 10	500	5000
10 × 10	24	10 × 10	500	5000
10 × 12.5	24	10 × 12.5	400	4000

Type	ØD×L	X	Y	Z
VR	6.3×7.7	1.6	3.5	2.0
	8×10	2.5	3.5	3.0
	10×10	2.5	4.0	4.0
	10×12.5	2.5	4.0	4.0
VG	6.3×7.7	3.0	4.0	1.6
	8×10	4.3	5.3	2.0
	10×10	4.3	5.6	3.3
	10×12.5	4.3	5.6	3.3

CONDUCTIVE POLYMER HYBRID ALUMINUM ELECTROLYTIC CAPACITORS

YC Chip type, Standard Series



- Endurance with ripple current: 10000 hours at 105°C
- Complied to the RoHS directive
- AEC-Q200 compliant : Please contact us for more details.

Item	Characteristics												
Operating temperature range	-55 ~ +105°C												
Leakage current max.	$I = 0.01CV$ or $3\mu A$ whichever is greater (after 2 minutes)												
Capacitance tolerance	$\pm 20\%$ at 120Hz, 20°C												
Dissipation factor max. (at 120Hz, 20°C)	<table border="1"> <tr> <td>WV</td> <td>16</td> <td>25</td> <td>35</td> <td>50</td> <td>63 ~ 100</td> </tr> <tr> <td>tanδ</td> <td>0.16</td> <td>0.14</td> <td>0.12</td> <td>0.10</td> <td>0.08</td> </tr> </table>	WV	16	25	35	50	63 ~ 100	tan δ	0.16	0.14	0.12	0.10	0.08
	WV	16	25	35	50	63 ~ 100							
tan δ	0.16	0.14	0.12	0.10	0.08								
Low temperature characteristics (Impedance ratio at 100kHz)	$Z (-25^\circ C) / Z (+20^\circ C) \leq 1.5$ $Z (-55^\circ C) / Z (+20^\circ C) \leq 2.0$												
Load life	After an application of DC bias voltage plus the rated AC ripple current for 10000 hours at 105°C. The measurement shall meet the following limits. The DC voltage plus the peak AC voltage combined must not exceed the rated voltage.												
	<table border="1"> <tr> <td>Capacitance change</td> <td>Within $\pm 30\%$ of initial value</td> </tr> <tr> <td>tanδ</td> <td>Less than 200% of the specified value</td> </tr> <tr> <td>ESR</td> <td>Less than 200% of the specified value</td> </tr> <tr> <td>Leakage current</td> <td>Less than specified value</td> </tr> </table>	Capacitance change	Within $\pm 30\%$ of initial value	tan δ	Less than 200% of the specified value	ESR	Less than 200% of the specified value	Leakage current	Less than specified value				
	Capacitance change	Within $\pm 30\%$ of initial value											
	tan δ	Less than 200% of the specified value											
ESR	Less than 200% of the specified value												
Leakage current	Less than specified value												
Shelf life (at 105°C)	After 1000 hours no load test, leakage current, capacitance and tan δ are same as load life value. The measurement shall be performed at 20°C by the KS C IEC 60384 - 4												
Resistance to soldering heat	The following specifications shall be satisfied when the capacitors are restored to 20°C after exposing them at 250°C for 10 seconds.												
	<table border="1"> <tr> <td>Leakage current</td> <td>Less than specified value</td> </tr> <tr> <td>Capacitance change</td> <td>Within $\pm 10\%$ of initial value</td> </tr> <tr> <td>tanδ</td> <td>Less than specified value</td> </tr> </table>	Leakage current	Less than specified value	Capacitance change	Within $\pm 10\%$ of initial value	tan δ	Less than specified value						
	Leakage current	Less than specified value											
Capacitance change	Within $\pm 10\%$ of initial value												
tan δ	Less than specified value												

DRAWING

Unit : mm

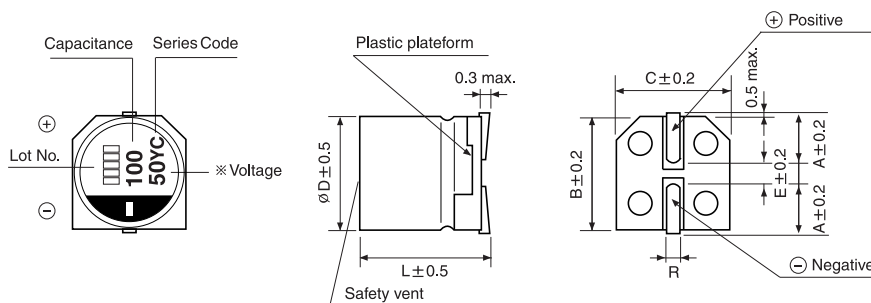

$\phi D \times L$	A	B	C	E	R
6.3×7.7	2.4	6.6	6.6	2.2	0.5~0.8
8×10	2.9	8.3	8.3	3.1	0.8~1.1
10×10	3.2	10.3	10.3	4.5	0.8~1.1
10×12.5	3.2	10.3	10.3	4.5	0.8~1.1

YC series

● DIMENSIONS & MAXIMUM PERMISSIBLE RIPPLE CURRENT

μF \diagdown WV	16			25			35		
47							6.3×7.7	35	2000
68				6.3×7.7	30	2000	6.3×7.7	35	2000
100				6.3×7.7	30	2000	8×10	27	2300
150	6.3×7.7	27	2200	8×10	27	2300	8×10	27	2300
							10×10	20	2500
220				8×10	27	2300			
270	8×10	22	2500	10×10	20	2500	10×10	20	2500
330				10×10	20	2500	10×12.5	17	2800
470	10×10	18	2600	10×12.5	16	2800			
560	10×12.5	14	3000						

μF \diagdown WV	50			63			80		
10				6.3×7.7	80	1500			
15	6.3×7.7	40	1600						
22				6.3×7.7	80	1500	8×10	45	1600
				8×10	40	1600			
33	6.3×7.7	40	1600	8×10	40	1600			
	8×10	30	1800	10×10	30	1800			
39							10×10	35	1700
47	8×10	30	1800				10×12.5	32	1800
56	10×10	25	2000	10×10	30	1800			
68	10×10	25	2000	10×12.5	22	2100			
100	10×10	25	2000						
150	10×12.5	19	2300						

μF \diagdown WV	100		
10	8×10	60	1450
15	10×10	45	1500
18	10×12.5	40	1580

↑ Ripple current (mA rms) at 105°C, 100kHz
 ↑ ESR (mΩ) at 20°C, 100kHz
 ↑ Case size $\varnothing D \times L$ (mm)

● FREQUENCY COEFFICIENT OF PERMISSIBLE RIPPLE CURRENT

Frequency	120Hz	1kHz	10kHz	100kHz
Coefficient	0.05	0.30	0.70	1.00

CONDUCTIVE POLYMER HYBRID ALUMINUM ELECTROLYTIC CAPACITORS

YH Chip type, High Temperature Series

S
Solvent Proof



- High temperature range, for 125°C use
- Complied to the RoHS directive
- AEC-Q200 compliant : Please contact us for more details.

Item	Characteristics												
Operating temperature range	-55 ~ +125°C												
Leakage current max.	$I = 0.01CV$ or $3\mu A$ whichever is greater (after 2 minutes)												
Capacitance tolerance	$\pm 20\%$ at 120Hz, 20°C												
Dissipation factor max. (at 120Hz, 20°C)	<table border="1"> <tr> <td>WV</td> <td>16</td> <td>25</td> <td>35</td> <td>50</td> <td>63 ~ 100</td> </tr> <tr> <td>tanδ</td> <td>0.16</td> <td>0.14</td> <td>0.12</td> <td>0.10</td> <td>0.08</td> </tr> </table>	WV	16	25	35	50	63 ~ 100	tan δ	0.16	0.14	0.12	0.10	0.08
	WV	16	25	35	50	63 ~ 100							
tan δ	0.16	0.14	0.12	0.10	0.08								
Low temperature characteristics (Impedance ratio at 100kHz)	$Z (-25^\circ C) / Z (+20^\circ C) \leq 1.5$ $Z (-55^\circ C) / Z (+20^\circ C) \leq 2.0$												
Load life	After an application of DC bias voltage plus the rated AC ripple current for 4000 hours at 125°C. The measurement shall meet the following limits. The DC voltage plus the peak AC voltage combined must not exceed the rated voltage.												
	<table border="1"> <tr> <td>Capacitance change</td> <td>Within $\pm 30\%$ of initial value</td> </tr> <tr> <td>tanδ</td> <td>Less than 200% of the specified value</td> </tr> <tr> <td>ESR</td> <td>Less than 200% of the specified value</td> </tr> <tr> <td>Leakage current</td> <td>Less than specified value</td> </tr> </table>	Capacitance change	Within $\pm 30\%$ of initial value	tan δ	Less than 200% of the specified value	ESR	Less than 200% of the specified value	Leakage current	Less than specified value				
	Capacitance change	Within $\pm 30\%$ of initial value											
	tan δ	Less than 200% of the specified value											
ESR	Less than 200% of the specified value												
Leakage current	Less than specified value												
Shelf life (at 125°C)	After 1000 hours no load test, leakage current, capacitance and tan δ are same as load life value. The measurement shall be performed at 20°C by the KS C IEC 60384 - 4												
Resistance to soldering heat	The following specifications shall be satisfied when the capacitors are restored to 20°C after exposing them at 250°C for 10 seconds.												
	<table border="1"> <tr> <td>Leakage current</td> <td>Less than specified value</td> </tr> <tr> <td>Capacitance change</td> <td>Within $\pm 10\%$ of initial value</td> </tr> <tr> <td>tanδ</td> <td>Less than specified value</td> </tr> </table>	Leakage current	Less than specified value	Capacitance change	Within $\pm 10\%$ of initial value	tan δ	Less than specified value						
	Leakage current	Less than specified value											
Capacitance change	Within $\pm 10\%$ of initial value												
tan δ	Less than specified value												

DRAWING

Unit : mm

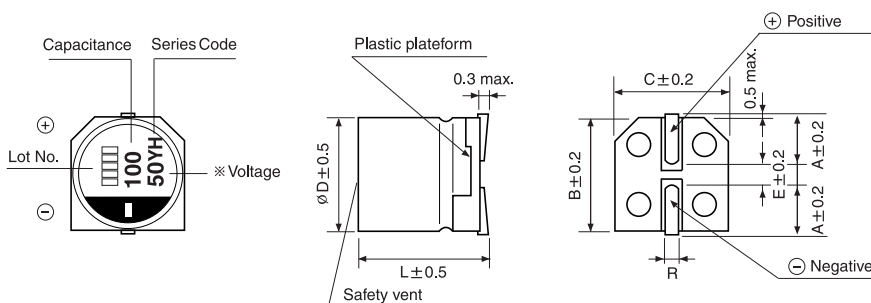

$\phi D \times L$	A	B	C	E	R
6.3 × 7.7	2.4	6.6	6.6	2.2	0.5~0.8
8 × 10	2.9	8.3	8.3	3.1	0.8~1.1
10 × 10	3.2	10.3	10.3	4.5	0.8~1.1
10 × 12.5	3.2	10.3	10.3	4.5	0.8~1.1

YH series

● DIMENSIONS & MAXIMUM PERMISSIBLE RIPPLE CURRENT

μF \diagdown WV	16			25			35		
47							6.3×7.7	35	1400
68				6.3×7.7	30	1400	6.3×7.7	35	1400
100				6.3×7.7	30	1400	8×10	27	1600
150	6.3×7.7	27	1450	8×10	27	1600	8×10	27	1600
							10×10	20	2000
220				8×10	27	1600			
270	8×10	22	1700	10×10	20	2000	10×10	20	2000
330				10×10	20	2000	10×12.5	17	2260
470	10×10	18	2100	10×12.5	16	2260			
560	10×12.5	14	2320						

μF \diagdown WV	50			63			80		
10				6.3×7.7	80	900			
15	6.3×7.7	40	1100						
22				6.3×7.7	80	900	8×10	45	1100
				8×10	40	1100			
33	6.3×7.7	40	1100	8×10	40	1100			
	8×10	30	1250	10×10	30	1400			
39							10×10	35	1200
47	8×10	30	1250				10×12.5	32	1400
56	10×10	25	1600	10×10	30	1400			
68	10×10	25	1600	10×12.5	22	1650			
100	10×10	25	1600						
150	10×12.5	19	1820						

μF \diagdown WV	100		
10	8×10	60	900
15	10×10	45	1120
18	10×12.5	40	1220

Ripple current (mA rms) at 125°C, 100kHz
 ESR (mΩ) at 20°C, 100kHz
 Case size $\varnothing D \times L$ (mm)

● FREQUENCY COEFFICIENT OF PERMISSIBLE RIPPLE CURRENT

Frequency	120Hz	1kHz	10kHz	100kHz
Coefficient	0.05	0.30	0.70	1.00

CONDUCTIVE POLYMER HYBRID ALUMINUM ELECTROLYTIC CAPACITORS

YK Chip type, High Temperature Series



- High temperature compared with YH series
- High temperature range, for 135°C use
- Complied to the RoHS directive
- AEC-Q200 compliant : Please contact us for more details.

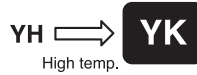

Item	Characteristics										
Operating temperature range	-55 ~ +135°C										
Leakage current max.	$I = 0.01CV$ or $3\mu A$ whichever is greater (after 2 minutes)										
Capacitance tolerance	$\pm 20\%$ at 120Hz, 20°C										
Dissipation factor max. (at 120Hz, 20°C)	<table border="1"> <tr> <td>WV</td> <td>25</td> <td>35</td> <td>50</td> <td>63</td> </tr> <tr> <td>tanδ</td> <td>0.14</td> <td>0.12</td> <td>0.10</td> <td>0.08</td> </tr> </table>	WV	25	35	50	63	tan δ	0.14	0.12	0.10	0.08
WV	25	35	50	63							
tan δ	0.14	0.12	0.10	0.08							
Low temperature characteristics (Impedance ratio at 100kHz)	$Z(-25^\circ C) / Z(+20^\circ C) \leq 1.5$ $Z(-55^\circ C) / Z(+20^\circ C) \leq 2.0$										
Load life	<p>After an application of DC bias voltage plus the rated AC ripple current for 4000 hours(2000 hours for $\phi D=6.3$) at 135°C. The measurement shall meet the following limits. The DC voltage plus the peak AC voltage combined must not exceed the rated voltage.</p> <table border="1"> <tr> <td>Capacitance change</td> <td>Within $\pm 30\%$ of initial value</td> </tr> <tr> <td>tanδ</td> <td>Less than 200% of the specified value</td> </tr> <tr> <td>ESR</td> <td>Less than 200% of the specified value</td> </tr> <tr> <td>Leakage current</td> <td>Less than specified value</td> </tr> </table>	Capacitance change	Within $\pm 30\%$ of initial value	tan δ	Less than 200% of the specified value	ESR	Less than 200% of the specified value	Leakage current	Less than specified value		
Capacitance change	Within $\pm 30\%$ of initial value										
tan δ	Less than 200% of the specified value										
ESR	Less than 200% of the specified value										
Leakage current	Less than specified value										
Shelf life (at 135°C)	After 1000 hours no load test, leakage current, capacitance and tan δ are same as load life value. The measurement shall be performed at 20°C by the KS C IEC 60384 - 4										
Resistance to soldering heat	<p>The following specifications shall be satisfied when the capacitors are restored to 20°C after exposing them at 250°C for 10 seconds.</p> <table border="1"> <tr> <td>Leakage current</td> <td>Less than specified value</td> </tr> <tr> <td>Capacitance change</td> <td>Within $\pm 10\%$ of initial value</td> </tr> <tr> <td>tanδ</td> <td>Less than specified value</td> </tr> </table>	Leakage current	Less than specified value	Capacitance change	Within $\pm 10\%$ of initial value	tan δ	Less than specified value				
Leakage current	Less than specified value										
Capacitance change	Within $\pm 10\%$ of initial value										
tan δ	Less than specified value										

● DRAWING

Unit : mm

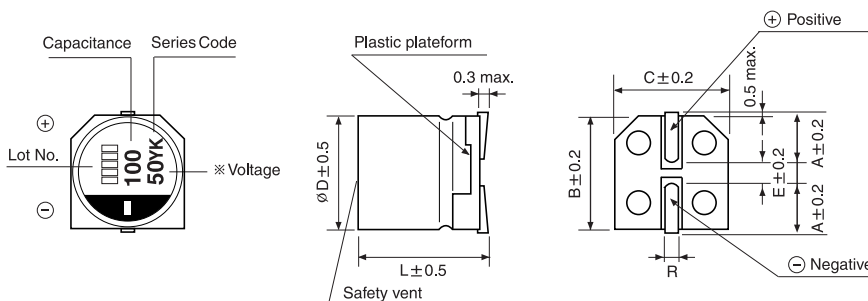

$\phi D \times L$	A	B	C	E	R
6.3×7.7	2.4	6.6	6.6	2.2	0.5~0.8
8×10	2.9	8.3	8.3	3.1	0.8~1.1
10×10	3.2	10.3	10.3	4.5	0.8~1.1
10×12.5	3.2	10.3	10.3	4.5	0.8~1.1

● DIMENSIONS & MAXIMUM PERMISSIBLE RIPPLE CURRENT

μF \ WV	25		35			50			63		
33									8×10	40	1100
47							8×10	30	1250		
56										10×10	30
68				6.3×7.7	35	1400					
82											
100	6.3×7.7	30	1400				10×10	25	1600		
150				8×10	27	1600					
220											
270	8×10	27	1600	10×10	20	2000					
330	10×10	20	2000	10×12.5	17	2260					
470	10×12.5	16	2260								

← Ripple current (mA rms) at 135°C, 100kHz

↑ ESR (mΩ) at 20°C, 100kHz
Case size $\phi D \times L$ (mm)

● FREQUENCY COEFFICIENT OF PERMISSIBLE RIPPLE CURRENT

Frequency	120Hz	1kHz	10kHz	100kHz
Coefficient	0.05	0.30	0.70	1.00

YT Chip type, Ultra High Temperature Series



- High temperature range, for 150°C use
- Complied to the RoHS directive
- AEC-Q200 compliant : Please contact us for more details.

Item	Characteristics										
Operating temperature range	-55 ~ +150°C										
Leakage current max.	$I = 0.01CV$ or $3\mu A$ whichever is greater (after 2 minutes)										
Capacitance tolerance	$\pm 20\%$ at 120Hz, 20°C										
Dissipation factor max. (at 120Hz, 20°C)	<table border="1"> <tr> <td>WV</td> <td>25</td> <td>35</td> <td>50</td> <td>63</td> </tr> <tr> <td>tanδ</td> <td>0.14</td> <td>0.12</td> <td>0.1</td> <td>0.08</td> </tr> </table>	WV	25	35	50	63	tan δ	0.14	0.12	0.1	0.08
WV	25	35	50	63							
tan δ	0.14	0.12	0.1	0.08							
Low temperature characteristics (Impedance ratio at 100kHz)	$Z (-25^\circ C) / Z (+20^\circ C) \leq 1.5$ $Z (-55^\circ C) / Z (+20^\circ C) \leq 2.0$										
Load life	After an application of DC bias voltage plus the rated AC ripple current for 1000 hours at 150°C. The measurement shall meet the following limits. The DC voltage plus the peak AC voltage combined must not exceed the rated voltage. <table border="1"> <tr> <td>Capacitance change</td> <td>Within $\pm 30\%$ of initial value</td> </tr> <tr> <td>tanδ</td> <td>Less than 200% of the specified value</td> </tr> <tr> <td>ESR</td> <td>Less than 200% of the specified value</td> </tr> <tr> <td>Leakage current</td> <td>Less than specified value</td> </tr> </table>	Capacitance change	Within $\pm 30\%$ of initial value	tan δ	Less than 200% of the specified value	ESR	Less than 200% of the specified value	Leakage current	Less than specified value		
Capacitance change	Within $\pm 30\%$ of initial value										
tan δ	Less than 200% of the specified value										
ESR	Less than 200% of the specified value										
Leakage current	Less than specified value										
Shelf life (at 150°C)	After 1000 hours no load test, leakage current, capacitance and tan δ are same as load life value. The measurement shall be performed at 20°C by the KS C IEC 60384 - 4										
Resistance to soldering heat	The following specifications shall be satisfied when the capacitors are restored to 20°C after exposing them at 250°C for 10 seconds. <table border="1"> <tr> <td>Leakage current</td> <td>Less than specified value</td> </tr> <tr> <td>Capacitance change</td> <td>Within $\pm 10\%$ of initial value</td> </tr> <tr> <td>tanδ</td> <td>Less than specified value</td> </tr> </table>	Leakage current	Less than specified value	Capacitance change	Within $\pm 10\%$ of initial value	tan δ	Less than specified value				
Leakage current	Less than specified value										
Capacitance change	Within $\pm 10\%$ of initial value										
tan δ	Less than specified value										

DRAWING

Unit : mm

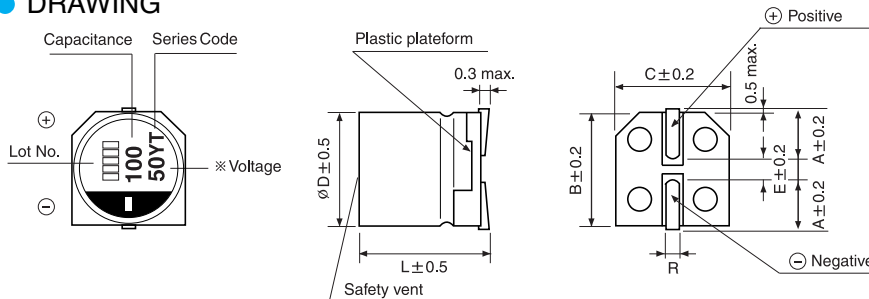

$\varnothing D \times L$	A	B	C	E	R
6.3×7.7	2.4	6.6	6.6	2.2	0.5~0.8
8×10	2.9	8.3	8.3	3.1	0.8~1.1
10×10	3.2	10.3	10.3	4.5	0.8~1.1
10×12.5	3.2	10.3	10.3	4.5	0.8~1.1

DIMENSIONS & MAXIMUM PERMISSIBLE RIPPLE CURRENT

μF	WV	25		35			50			63		
15									6.3×7.7	80	410	
22							6.3×7.7	80	410			
33												
47				6.3×7.7	60	510						
56							8×10	35	660	10×10	30	710
68	6.3×7.7	45	540							10×12.5	22	810
100				8×10	30	710	10×10	28	780			
120							10×12.5	19	890			
150	8×10	27	740	10×10	23	830						
220				10×12.5	17	950						
270	10×10	22	850									
330	10×12.5	16	970									

Ripple current (mA rms) at 150°C, 100kHz
 ESR (m Ω) at 20°C, 100kHz
 Case size $\varnothing D \times L$ (mm)

FREQUENCY COEFFICIENT OF PERMISSIBLE RIPPLE CURRENT

Frequency	120Hz	1kHz	10kHz	100kHz
Coefficient	0.05	0.30	0.70	1.00

CONDUCTIVE POLYMER HYBRID ALUMINUM ELECTROLYTIC CAPACITORS

YM Chip type, High Capacitance & High Ripple Current Series



- High ripple current compared with YH series
- High temperature range, for 125°C use
- Complied to the RoHS directive
- AEC-Q200 compliant : Please contact us for more details.



Item	Characteristics												
Operating temperature range	-55 ~ +125°C												
Leakage current max.	$I = 0.01CV$ or $3\mu A$ whichever is greater (after 2 minutes)												
Capacitance tolerance	$\pm 20\%$ at 120Hz, 20°C												
Dissipation factor max. (at 120Hz, 20°C)	<table border="1"> <tr> <td>WV</td> <td>16</td> <td>25</td> <td>35</td> <td>50</td> <td>63</td> </tr> <tr> <td>tanδ</td> <td>0.16</td> <td>0.14</td> <td>0.12</td> <td>0.1</td> <td>0.08</td> </tr> </table>	WV	16	25	35	50	63	tan δ	0.16	0.14	0.12	0.1	0.08
	WV	16	25	35	50	63							
tan δ	0.16	0.14	0.12	0.1	0.08								
Low temperature characteristics (Impedance ratio at 100kHz)	$Z(-25^\circ C) / Z(+20^\circ C) \leq 1.5$ $Z(-55^\circ C) / Z(+20^\circ C) \leq 2.0$												
Load life	After an application of DC bias voltage plus the rated AC ripple current for 4000 hours at 125°C. The measurement shall meet the following limits. The DC voltage plus the peak AC voltage combined must not exceed the rated voltage.												
	Capacitance change	Within $\pm 30\%$ of initial value											
	tan δ	Less than 200% of the specified value											
	ESR	Less than 200% of the specified value											
Shelf life (at 125°C)	After 1000 hours no load test, leakage current, capacitance and tan δ are same as load life value. The measurement shall be performed at 20°C by the KS C IEC 60384 - 4												
	Resistance to soldering heat	The following specifications shall be satisfied when the capacitors are restored to 20°C after exposing them at 250°C for 10 seconds.											
Resistance to soldering heat	Leakage current	Less than specified value											
	Capacitance change	Within $\pm 10\%$ of initial value											
	tan δ	Less than specified value											

DRAWING

Unit : mm

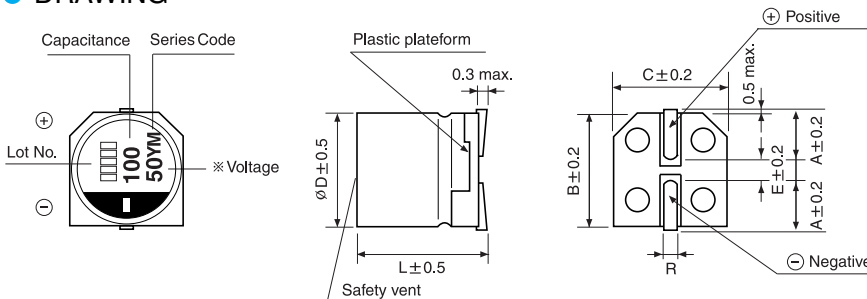

$\phi D \times L$	A	B	C	E	R
6.3×7.7	2.4	6.6	6.6	2.2	0.5~0.8
8×10	2.9	8.3	8.3	3.1	0.8~1.1
10×10	3.2	10.3	10.3	4.5	0.8~1.1
10×12.5	3.2	10.3	10.3	4.5	0.8~1.1

DIMENSIONS & MAXIMUM PERMISSIBLE RIPPLE CURRENT

μF	WV	16		25		35		50		63	
47								6.3×7.7	40	1500	
82											8×10
100											10×10
150	6.3×7.7	27	1800	6.3×7.7	30	1800	6.3×7.7	35	1700		10×12.5
220							8×10	27	2000		
330				8×10	27	2000	10×10	20	2800		
390	8×10	22	2000				10×12.5	17	3500		
560				10×10	20	2800					
680	10×10	18	2800	10×12.5	16	3500					
820	10×12.5	14	3500								

Ripple current (mA rms) at 125°C, 100kHz
 ESR (m Ω) at 20°C, 100kHz
 Case size $\phi D \times L$ (mm)

FREQUENCY COEFFICIENT OF PERMISSIBLE RIPPLE CURRENT

Frequency	120Hz	1kHz	10kHz	100kHz
Coefficient	0.05	0.30	0.70	1.00

YB Lead type, Standard Series

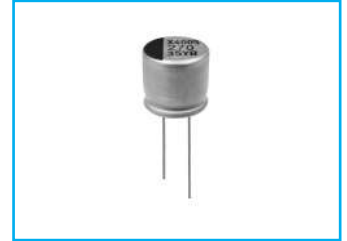

- Endurance with ripple current: 10000 hours at 105°C
- Complied to the RoHS directive
- AEC-Q200 compliant : Please contact us for more details.

Item	Characteristics					
Operating temperature range	-55 ~ +105°C					
Leakage current max.	$I = 0.01CV$ or $3\mu A$ whichever is greater (after 2 minutes)					
Capacitance tolerance	$\pm 20\%$ at 120Hz, 20°C					
Dissipation factor max. (at 120Hz, 20°C)	WV	16	25	35	50	63 ~ 100
	tan δ	0.16	0.14	0.12	0.10	0.08
Low temperature characteristics (Impedance ratio at 100kHz)	$Z (-25^\circ C) / Z (+20^\circ C) \leq 1.5$ $Z (-55^\circ C) / Z (+20^\circ C) \leq 2.0$					
Load life	After an application of DC bias voltage plus the rated AC ripple current for 10000 hours at 105°C. The measurement shall meet the following limits. The DC voltage plus the peak AC voltage combined must not exceed the rated voltage.					
	Capacitance change	Within $\pm 30\%$ of initial value				
	tan δ	Less than 200% of the specified value				
	ESR	Less than 200% of the specified value				
Leakage current	Less than specified value					
	After 1000 hours no load test, leakage current, capacitance and tan δ are same as load life value. The measurement shall be performed at 20°C by the KS C IEC 60384 - 4					
Shelf life(at 105°C)	After 1000 hours no load test, leakage current, capacitance and tan δ are same as load life value. The measurement shall be performed at 20°C by the KS C IEC 60384 - 4					

DRAWING

Unit : mm

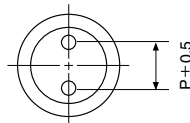
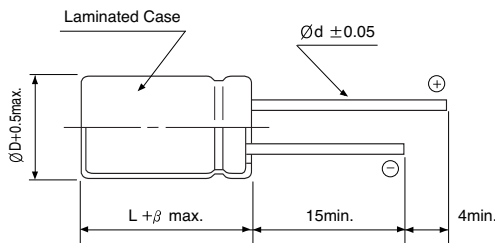

Size	ØD	L	P	Ød	β
6.3×7.5	6.3	7.5	2.5	0.45	1.5
8×9.5	8	9.5	3.5	0.60	1.5
10×9.5	10.0	9.5	5.0	0.60	1.5
10×12	10.0	12.0	5.0	0.60	1.5

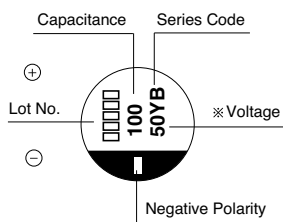

PACKING & TAPING (See page 84~86)

CONDUCTIVE POLYMER HYBRID ALUMINUM ELECTROLYTIC CAPACITORS

YB series

● DIMENSIONS & MAXIMUM PERMISSIBLE RIPPLE CURRENT

μF \diagdown WV	16			25			35		
47							6.3×7.5	35	2000
68				6.3×7.5	30	2000	6.3×7.5	35	2000
100				6.3×7.5	30	2000	8×9.5	27	2300
150	6.3×7.5	27	2200	8×9.5	27	2300	8×9.5	27	2300
							10×9.5	20	2500
220				8×9.5	27	2300			
270	8×9.5	22	2500	10×9.5	20	2500	10×9.5	20	2500
330				10×9.5	20	2500	10×12	17	2800
470	10×9.5	18	2600	10×12	16	2800			
560	10×12	14	3000						

μF \diagdown WV	50			63			80		
10				6.3×7.5	80	1500			
15	6.3×7.5	40	1600						
22				6.3×7.5	80	1500	8×9.5	45	1600
				8×9.5	40	1600			
33	6.3×7.5	40	1600	8×9.5	40	1600			
	8×9.5	30	1800	10×9.5	30	1800			
39							10×9.5	35	1700
47	8×9.5	30	1800				10×12	32	1800
56	10×9.5	25	2000	10×9.5	30	1800			
68	10×9.5	25	2000	10×12	22	2100			
100	10×9.5	25	2000						
150	10×12	19	2300						

μF \diagdown WV	100		
10	8×9.5	60	1450
15	10×9.5	45	1500
18	10×12	40	1580

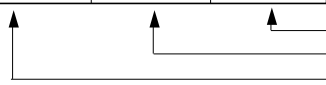
 Ripple current (mA rms) at 105°C, 100kHz
 ESR (mΩ) at 20°C, 100kHz
 Case size $\varnothing D \times L$ (mm)

● FREQUENCY COEFFICIENT OF PERMISSIBLE RIPPLE CURRENT

Frequency	120Hz	1kHz	10kHz	100kHz
Coefficient	0.05	0.30	0.70	1.00

YG Lead type, High Temperature Series

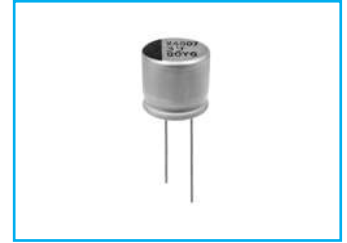

- High temperature range, for 125°C use
- Complied to the RoHS directive
- AEC-Q200 compliant : Please contact us for more details.

Item	Characteristics					
Operating temperature range	-55 ~ +125°C					
Leakage current max.	I = 0.01CV or 3μA whichever is greater (after 2 minutes)					
Capacitance tolerance	±20% at 120Hz, 20°C					
Dissipation factor max. (at 120Hz, 20°C)	WV	16	25	35	50	63 ~ 100
	tanδ	0.16	0.14	0.12	0.10	0.08
Low temperature characteristics (Impedance ratio at 100kHz)	Z (-25°C) / Z (+20°C) ≤ 1.5 Z (-55°C) / Z (+20°C) ≤ 2.0					
Load life	After an application of DC bias voltage plus the rated AC ripple current for 4000 hours at 125°C. The measurement shall meet the following limits. The DC voltage plus the peak AC voltage combined must not exceed the rated voltage.					
	Capacitance change	Within ±30% of initial value				
	tanδ	Less than 200% of the specified value				
	ESR	Less than 200% of the specified value				
Shelf life (at 125°C)	After 1000 hours no load test, leakage current, capacitance and tanδ are same as load life value. The measurement shall be performed at 20°C by the KS C IEC 60384 - 4					

HYBRID TYPES

● DRAWING

Unit : mm

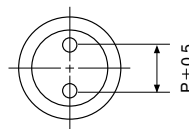
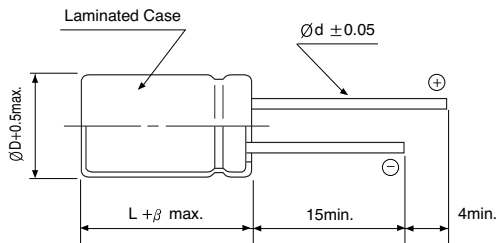

Size	ØD	L	P	Ød	β
6.3×7.5	6.3	7.5	2.5	0.45	1.5
8×9.5	8	9.5	3.5	0.60	1.5
10×9.5	10.0	9.5	5.0	0.60	1.5
10×12	10.0	12.0	5.0	0.60	1.5

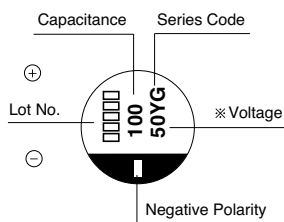

● PACKING & TAPING (See page 84~86)

CONDUCTIVE POLYMER HYBRID ALUMINUM ELECTROLYTIC CAPACITORS

YG series

● DIMENSIONS & MAXIMUM PERMISSIBLE RIPPLE CURRENT

μF \diagdown WV	16			25			35		
47							6.3×7.5	35	1400
68				6.3×7.5	30	1400	6.3×7.5	35	1400
100				6.3×7.5	30	1400	8×9.5	27	1600
150	6.3×7.5	27	1450	8×9.5	27	1600	8×9.5	27	1600
							10×9.5	20	2000
220				8×9.5	27	1600			
270	8×9.5	22	1700	10×9.5	20	2000	10×9.5	20	2000
330				10×9.5	20	2000	10×12	17	2260
470	10×9.5	18	2100	10×12	16	2260			
560	10×12	14	2320						

μF \diagdown WV	50			63			80		
10				6.3×7.5	80	900			
15	6.3×7.5	40	1100						
22				6.3×7.5	80	900	8×9.5	45	1100
				8×9.5	40	1100			
33	6.3×7.5	40	1100	8×9.5	40	1100			
	8×9.5	30	1250	10×9.5	30	1400			
39							10×9.5	35	1200
47	8×9.5	30	1250				10×12	32	1400
56	10×9.5	25	1600	10×9.5	30	1400			
68	10×9.5	25	1600	10×12	22	1650			
100	10×9.5	25	1600						
150	10×12	19	1820						

μF \diagdown WV	100		
10	8×9.5	60	900
15	10×9.5	45	1120
18	10×12	40	1220

Ripple current (mA rms) at 125°C, 100kHz
 ESR (mΩ) at 20°C, 100kHz
 Case size $\varnothing D \times L$ (mm)

● FREQUENCY COEFFICIENT OF PERMISSIBLE RIPPLE CURRENT

Frequency	120Hz	1kHz	10kHz	100kHz
Coefficient	0.05	0.30	0.70	1.00

New

YJ

Lead type, High Temperature Series

- High temperature compared with YG series
- High temperature range, for 135°C use
- Complied to the RoHS directive

YG ⇒ YJ
High Temp.

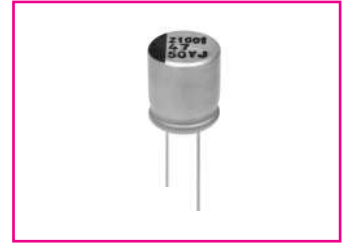

Item	Characteristics				
Operating temperature range	-55 ~ +135°C				
Leakage current max.	I = 0.01CV or 3μA whichever is greater (after 2 minutes)				
Capacitance tolerance	±20% at 120Hz, 20°C				
Dissipation factor max. (at 120Hz, 20°C)	WV	25	35	50	63
	tanδ	0.14	0.12	0.1	0.08
Low temperature characteristics (Impedance ratio at 100kHz)	$Z(-25^{\circ}\text{C}) / Z(+20^{\circ}\text{C}) \leq 1.5$ $Z(-55^{\circ}\text{C}) / Z(+20^{\circ}\text{C}) \leq 2.0$				
Load life	After an application of DC bias voltage plus the rated AC ripple current for 4000 hours(2000 hours for ØD=6.3) at 135°C. The measurement shall meet the following limits. The DC voltage plus the peak AC voltage combined must not exceed the rated voltage.				
	Capacitance change	Within ±30% of initial value			
	tanδ	Less than 200% of the specified value			
	ESR	Less than 200% of the specified value			
Shelf life(at 135°C)	After 1000 hours no load test, leakage current, capacitance and tanδ are same as load life value. The measurement shall be performed at 20°C by the KS C IEC 60384 - 4				

HYBRID TYPES

● DRAWING

Unit : mm

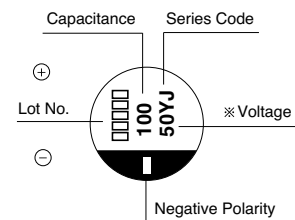
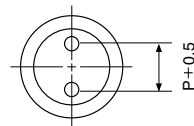
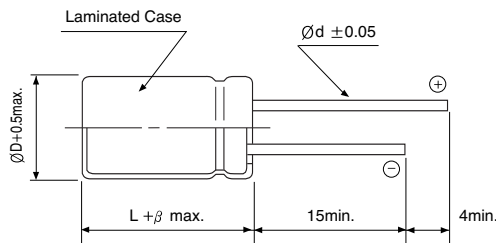

Size	ØD	L	P	Ød	β
6.3×7.5	6.3	7.5	2.5	0.45	1.5
8×9.5	8	9.5	3.5	0.60	1.5
10×9.5	10.0	9.5	5.0	0.60	1.5
10×12	10.0	12.0	5.0	0.60	1.5

● PACKING & TAPING (See page 84~86)

CONDUCTIVE POLYMER HYBRID ALUMINUM ELECTROLYTIC CAPACITORS

YJ series

● DIMENSIONS & MAXIMUM PERMISSIBLE RIPPLE CURRENT

μF \diagdown WV	25			35			50			63		
33										8×9.5	40	1100
47							8×9.5	30	1250			
56										10×9.5	30	1400
68				6.3×7.5	35	1400						
82												
100	6.3×7.5	30	1400				10×9.5	25	1600			
150				8×9.5	27	1600						
220												
270	8×9.5	27	1600	10×9.5	20	2000						
330	10×9.5	20	2000	10×12	17	2260						
470	10×12	16	2260									

Ripple current (mA rms) at 135°C, 100kHz
 ESR (mΩ) at 20°C, 100kHz
 Case size $\varnothing D \times L$ (mm)

● FREQUENCY COEFFICIENT OF PERMISSIBLE RIPPLE CURRENT

Frequency	120Hz	1kHz	10kHz	100kHz
Coefficient	0.05	0.30	0.70	1.00

YF Lead type, Ultra High Temperature Series

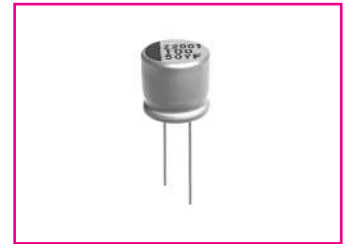

- High temperature range, for 150°C use
- Complied to the RoHS directive
- AEC-Q200 compliant : Please contact us for more details.

Item	Characteristics				
Operating temperature range	-55 ~ +150°C				
Leakage current max.	$I = 0.01CV$ or $3\mu A$ whichever is greater (after 2 minutes)				
Capacitance tolerance	$\pm 20\%$ at 120Hz, 20°C				
Dissipation factor max. (at 120Hz, 20°C)	WV	25	35	50	63
	$\tan\delta$	0.14	0.12	0.1	0.08
Low temperature characteristics (Impedance ratio at 100kHz)	$Z(-25^\circ C) / Z(+20^\circ C) \leq 1.5$ $Z(-55^\circ C) / Z(+20^\circ C) \leq 2.0$				
Load life	After an application of DC bias voltage plus the rated AC ripple current for 1000 hours at 150°C. The measurement shall meet the following limits. The DC voltage plus the peak AC voltage combined must not exceed the rated voltage.				
	Capacitance change	Within $\pm 30\%$ of initial value			
	$\tan\delta$	Less than 200% of the specified value			
	ESR	Less than 200% of the specified value			
Leakage current	Less than specified value				
Shelf life(at 150°C)	After 1000 hours no load test, leakage current, capacitance and $\tan\delta$ are same as load life value. The measurement shall be performed at 20°C by the KS C IEC 60384 - 4				

HYBRID TYPES

● DRAWING

Unit : mm

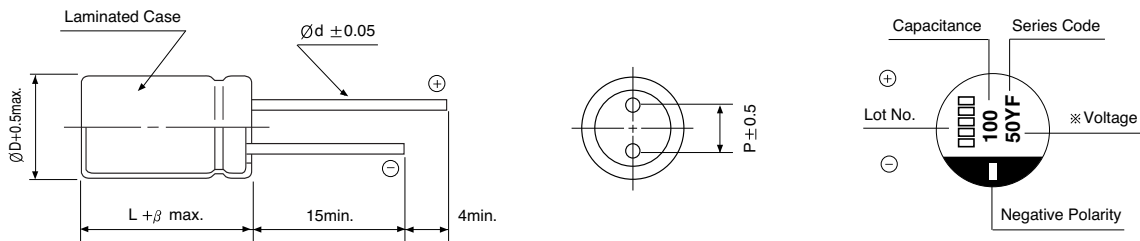

Size	ϕD	L	P	ϕd	β
6.3×7.5	6.3	7.5	2.5	0.45	1.5
8×9.5	8	9.5	3.5	0.60	1.5
10×9.5	10.0	9.5	5.0	0.60	1.5
10×12	10.0	12.0	5.0	0.60	1.5

● PACKING & TAPING (See page 84~86)

● DIMENSIONS & MAXIMUM PERMISSIBLE RIPPLE CURRENT

μF \ WV	25		35			50			63		
15									6.3×7.5	80	410
22						6.3×7.5	80	410			
33									8×9.5	40	610
47			6.3×7.5	60	510						
56						8×9.5	35	660	10×9.5	30	710
68	6.3×7.5	45	540						10×12	22	810
100				8×9.5	30	710	10×9.5	28	780		
120							10×12	19	890		
150	8×9.5	27	740	10×9.5	23	830					
220				10×12	17	950					
270	10×9.5	22	850								
330	10×12	16	970								

↑ Ripple current (mA rms) at 150°C, 100kHz
 ↑ ESR (mΩ) at 20°C, 100kHz
 ↑ Case size $\phi D \times L$ (mm)

● FREQUENCY COEFFICIENT OF PERMISSIBLE RIPPLE CURRENT

Frequency	120Hz	1kHz	10kHz	100kHz
Coefficient	0.05	0.30	0.70	1.00

CONDUCTIVE POLYMER HYBRID ALUMINUM ELECTROLYTIC CAPACITORS

YL Lead type, High Capacitance & High Ripple Current Series

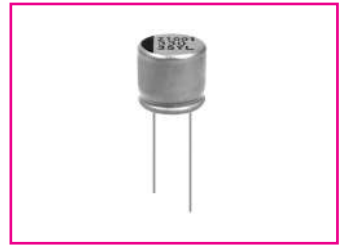

- High ripple current compared with YG series
- High temperature range, for 125°C use
- Complied to the RoHS directive
- AEC-Q200 compliant : Please contact us for more details.



Item	Characteristics												
Operating temperature range	-55 ~ +125°C												
Leakage current max.	$I = 0.01CV$ or $3\mu A$ whichever is greater (after 2 minutes)												
Capacitance tolerance	$\pm 20\%$ at 120Hz, 20°C												
Dissipation factor max. (at 120Hz, 20°C)	<table border="1"> <tr> <td>WV</td> <td>16</td> <td>25</td> <td>35</td> <td>50</td> <td>63</td> </tr> <tr> <td>tanδ</td> <td>0.16</td> <td>0.14</td> <td>0.12</td> <td>0.1</td> <td>0.08</td> </tr> </table>	WV	16	25	35	50	63	tanδ	0.16	0.14	0.12	0.1	0.08
	WV	16	25	35	50	63							
tanδ	0.16	0.14	0.12	0.1	0.08								
Low temperature characteristics (Impedance ratio at 100kHz)	$Z(-25^\circ C) / Z(+20^\circ C) \leq 1.5$ $Z(-55^\circ C) / Z(+20^\circ C) \leq 2.0$												
Load life	After an application of DC bias voltage plus the rated AC ripple current for 4000 hours at 125°C. The measurement shall meet the following limits. The DC voltage plus the peak AC voltage combined must not exceed the rated voltage.												
	<table border="1"> <tr> <td>Capacitance change</td> <td>Within $\pm 30\%$ of initial value</td> </tr> <tr> <td>tanδ</td> <td>Less than 200% of the specified value</td> </tr> <tr> <td>ESR</td> <td>Less than 200% of the specified value</td> </tr> <tr> <td>Leakage current</td> <td>Less than specified value</td> </tr> </table>	Capacitance change	Within $\pm 30\%$ of initial value	tanδ	Less than 200% of the specified value	ESR	Less than 200% of the specified value	Leakage current	Less than specified value				
	Capacitance change	Within $\pm 30\%$ of initial value											
	tanδ	Less than 200% of the specified value											
ESR	Less than 200% of the specified value												
Leakage current	Less than specified value												
Shelf life (at 125°C)	After 1000 hours no load test, leakage current, capacitance and tanδ are same as load life value. The measurement shall be performed at 20°C by the KS C IEC 60384 - 4												

● DRAWING

Unit : mm

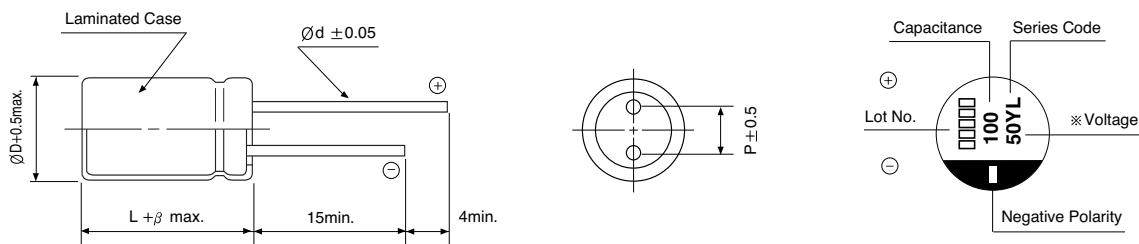

Size	$\varnothing D$	L	P	$\varnothing d$	β
6.3×7.5	6.3	7.5	2.5	0.45	1.5
8×9.5	8	9.5	3.5	0.60	1.5
10×9.5	10.0	9.5	5.0	0.60	1.5
10×12	10.0	12.0	5.0	0.60	1.5

● PACKING & TAPING (See page 84~86)

● DIMENSIONS & MAXIMUM PERMISSIBLE RIPPLE CURRENT

μF \ WV	16		25		35		50		63				
47							6.3×7.5	40	1500	8×9.5	40	1700	
82										10×9.5	30	2000	
100					6.3×7.5	35	1700	8×9.5	30	1700	10×12	22	3000
150	6.3×7.5	27	1800	6.3×7.5	30	1800	8×9.5	27	2000	10×9.5	25	2000	
220										10×12	19	3200	
330				8×9.5	27	2000	10×9.5	20	2800				
390	8×9.5	22	2000				10×12	17	3500				
560				10×9.5	20	2800							
680	10×9.5	18	2800	10×12	16	3500							
820	10×12	14	3500										

